

**TOP BOWL/DISCHARGE FLANGE**

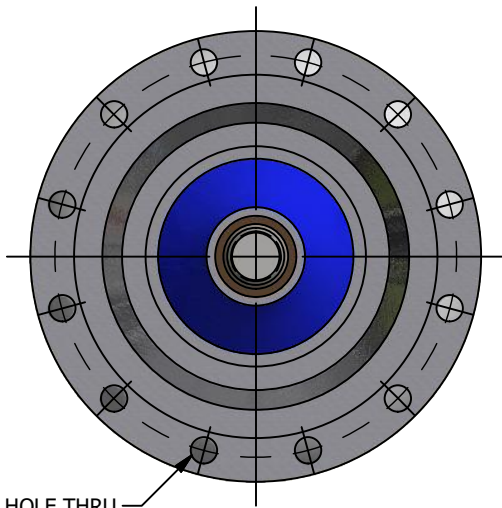

"A" X "B" HOLE THRU  
EQ. SP. ON "C" B.C.

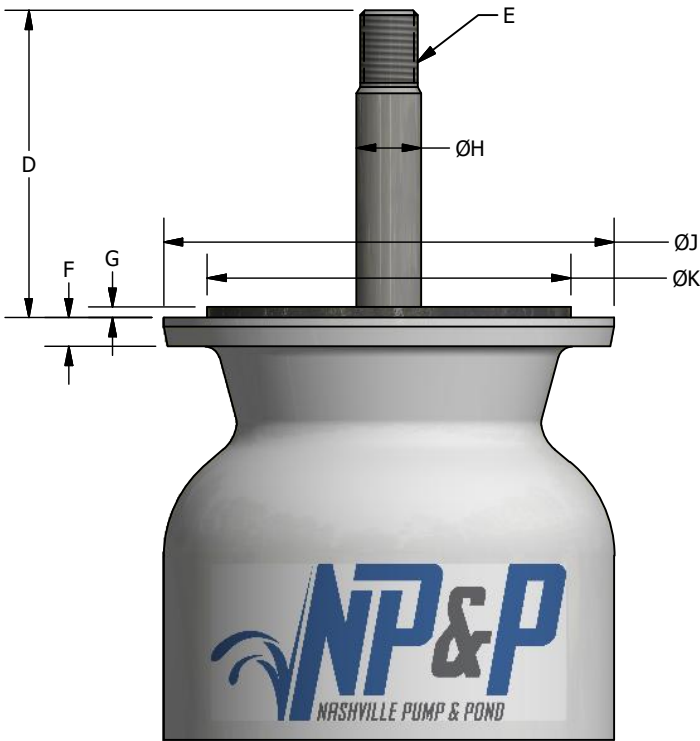

**FLANGE COLUMN PIPE (BOWL END)**

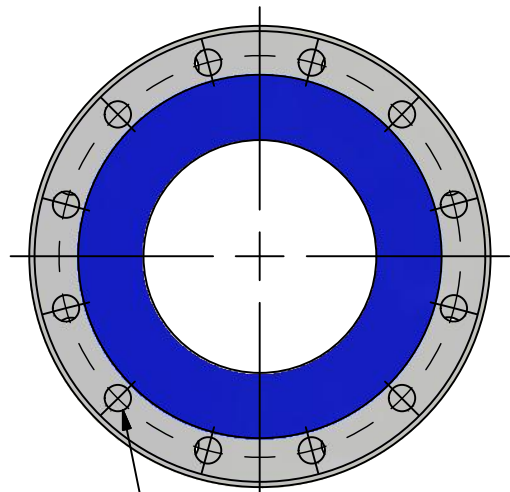
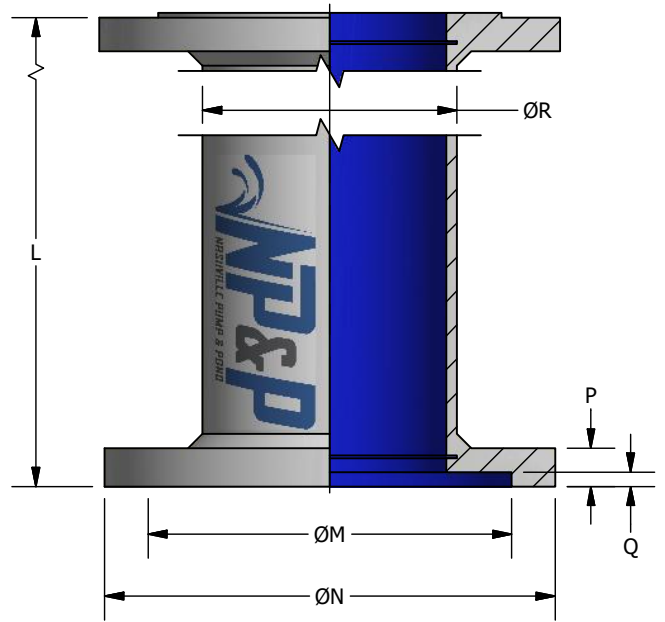

"R" X "S" HOLES "T" DEEP  
EQ. SP. ON "U" B.C.

**BOWL/DISCHARGE DIMENSIONS**

A	B	C	D	E
F	G	H	J	K

**COLUMN PIPE DIMENSIONS**

L	M	N	P	Q
R	S	T	U	R

**NOTICE**

THIS DRAWING IS THE CONFIDENTIAL PROPERTY OF NASHVILLE PUMP & POND, LLC, AND IS FURNISHED FOR YOUR INFORMATION ONLY AND MUST NOT BE MADE PUBLIC OR COPIED AND MUST BE RETURNED ON DEMAND. MANUFACTURE OF PARTS PER THIS DRAWING IS EXPRESSLY FORBIDDEN EXCEPT BY THE WRITTEN AUTHORIZATION FROM NASHVILLE PUMP & POND, LLC. ALL RIGHTS OF DESIGN AND INVENTION ARE RESERVED AND PATENTS PENDING.

REV	DATE	REVISION	CH

MATERIAL: Stainless Steel	TOLERANCES UNLESS OTHERWISE NOTED X.XXX ±0.005 X.XX ±0.010 X.X ±0.1 DEG ±0.5
REF ECN.:	
REF CAST DRWN:	



NASHVILLE PUMP & POND, LLC  
NASHVILLE, TN  
PHONE: 615.835.3145  
INFO@NASHVILLEPOND.COM  
WWW.NASHVILLEPOND.COM

DESCRIPTION:  
**NP&P TOP BOWL FLANGE & COLUMN FLANGE - DIMENSIONAL OVERVIEW**

CUSTOMER NAME:	PART No.:
CUSTOMER P O No.:	DWG. No. BOWL.ipt
DRN BY: DATE: 1/25/2017	SHT. 1 of 1
CKD BY:	REV.